

## Three-Tone Ringer for Telephone Sets

### Description

The three-tone ringing integrated circuit U4076B, in conjunction with a piezo transducer or loudspeaker replaces the normal electromechanical telephone bell. It is operated with the ringing current from the exchange. There is

also a possibility of operating the IC with the dc supply voltage, being developed for large operating range. The integrated circuit is overload protected.

### Features

- Three-tone ringing sequence with 800 Hz, 1067 Hz and 1333 Hz
- Sequence frequency adjustable between 2.5 Hz and 25 Hz
- Adjustable volume
- Push-pull output stage
- Piezo transducer or loudspeaker connection
- Common input for frequency and call recognition

- Reduced pulse duration for electromagnetic transducers
- Clock oscillator with ceramic resonator or LC series cct possible
- Input protective diode
- On-chip rectifier bridge
- Protection circuit against ringing in a parallel circuit

### Benefit

- Suitable for German Post Office Specification, FTZ 121671 Pfl. 3, edition dated 24.03.82

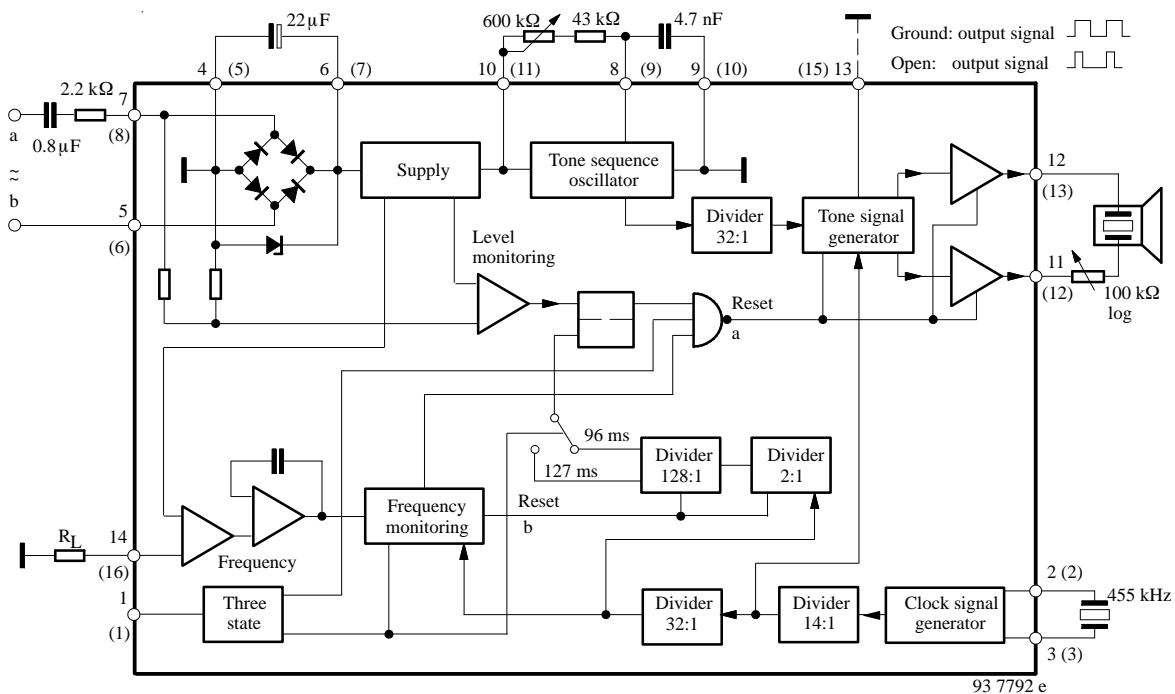

Case: DIP 14 or SO 16-L (Pin connections for SO 16-L case in bracket)

Figure 1. Block diagram and application circuit

## Pin Description

Pin	Symbol	Function
1 (1)		Frequency monitoring Open: 23 to 54 Hz Ground: 12 to 54 Hz With Pin 6 (7) connected: Switched off
2, 3 (2, 3)		Clock signal generator
4 (5)		Ground
5, 7 (6, 8)		Power supply
6 (7)		Charging capacitor, $C_L$ , for bridge rectifier
(8, 9, 10)		Frequency oscillator

Pin	Symbol	Function
8, 9, 10		Tone sequence
(9, 10, 11)		Frequency oscillator
11, 12 (12, 13)		Output signals
13 (15)		Output signal shape Open = short pulse width Ground = 1:1
14 (16)		Load resistance, $R_L$
(4, 14)		Not connected

## Pin Connections and Functional Description Including External Circuitry

### Pin 1: Frequency monitoring

Frequency is monitored via Pin 1. The following possibilities are available (three-state logic):

- Pin 1 is open: ringing frequency is between 23 and 54 Hz.
- Pin 1 is grounded: ringing frequency is between 12 and 54 Hz.
- Pin 1 is connected to Pin 6 (7): ringing frequency has no influence (dc operation)

### Pins 2 and 3 (2, 3): Clock signal generator

A ceramic resonator for a frequency of 455 kHz must be connected between Pin 2 (2) and Pin 3 (3). The clock frequency of the generator is used for three-tone ringing sequence and control signals for frequency identification.

### Pin 4 (5): Ground

Reference point for all voltages.

### Pins 5, 6 and 7 (6, 7, 8): Power supply

Pins 5 (6) and 7 (8) connect the circuit with a ringing ac supplied by the exchange via lines a and b. A decoupling capacitor of 1  $\mu$ F in series with 2.2 k $\Omega$  resistance is needed for overvoltage protection and the insertion loss requirement of the German Post Office specifications. The supplied ac current is rectified by the on-chip bridge circuit. The rectified current charges the capacitor on Pin 6 (7), which supplies the dc voltage for the integrated circuit. Instead of a ringing ac current supplied by the ex-

change, the IC can be driven by a dc voltage applied directly to terminals 6 (7) (+) and 4 (5) (-). An integrated Z diode limits the maximum supply voltage range up to 27 V.

### Pins 8, 9 and 10 (9, 10, 11): Sequence frequency adjustment

The sequence of the three-tone ringing frequency (800, 1067 and 1333 Hz) is determined by the external network calculated as follow:

$$f_2 = \frac{f_{osc}}{192} \quad \text{whereas} \quad f_{osc} = \frac{IC}{(43 \text{ k}\Omega + R_v) 47 \text{ nF}}$$

$$\begin{aligned} \text{if: } k \approx 0.95 & \quad \text{then } R_v = & 0 \text{ to } 20 \text{ k}\Omega \\ \text{if: } k \approx 1 & \quad \text{then } R_v = & 30 \text{ to } 150 \text{ k}\Omega \\ \text{if: } k \approx 1.2 & \quad \text{then } R_v > & 200 \text{ k}\Omega \end{aligned}$$

The sequence frequency adjustment is determined by the frequency prescaler ratio in the IC.

### Pins 11 and 12 (12, 13): Output signal

The three-tone ringing sequence of 800 Hz, 1067 Hz and 1333 Hz is realized if the clock oscillator is synchronised with a ceramic resonator of 455 kHz between Pins 2 (2) and Pin 3 (3). This gives excellent tone frequency and eliminates complicated frequency setting procedures. The output signal without load is  $(2 V_{6(7)} - 2.5) V_{pp}$ . The output stage transducers in BTL configuration can process an average current of up to 20 mA, whereas a short time current of 40 mA is possible in both direction when  $t = 0.1$  ms. An external current limitation is necessary when the IC is operating with voltage between Pin 6(7) and Pin 4 (5). The tone sequence always starts at the lower frequency.

## Pin 13 (15): Output signal shape

Output signal has different duty cycles according to the position of Pin 13 (15). When grounded it has a duty cycle of 1:1. When using a dynamic loudspeaker (activation via transformer/capacitor), a reduced signal is recommended. This can be achieved by connecting a capacitor greater than 1 nF between Pin 13 (15) and ground.

## Pin 14 (16): Switched on/off

Switched on/off is controlled by Pin 14 (16). The dc voltage on the charge capacitor between Pin 4 (5) and 6 (7) is loaded a dummy load as long as the tone ringing is not switched-on. In on-position (amplitude and frequency recognition), Pin 14 (16) is connected internally with

Pin 4 (5) and the dummy load is switched-off. In off-position, Pin 14 (16) is connected with Pin 6 (7) internally and the dummy load is switched on.

## Overload protection

The integrated circuit can withstand an ac voltage of 110 V / 50 Hz for 15 seconds between terminals a and b.

The circuit will not be damaged by a surge voltage test with the following conditions:

Charging voltage of surge capacitance:  $V_{CS} = 2 \text{ kV}$

Pulse shape: 10/700  $\mu\text{s}$

Pulse sequence: 30 s

No of surges: 10

Polarity change after five surges

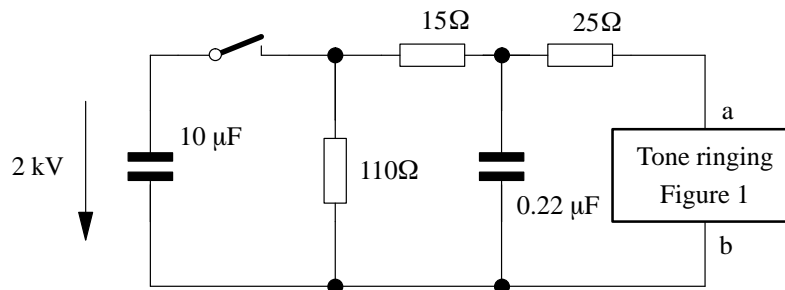

93 7575 e

Figure 2. Surge voltage test circuit

## Absolute Maximum Ratings

Reference point Pin 4 (5) unless otherwise specified

Parameters	Symbol	Value	Unit
Supply current Pins 5 and 7 (6, 8)	$I_S$	50	mA
Output current Pins 11 and 12 (12, 13)	$\pm I_0$	50	mA
Junction temperature	$T_j$	125	$^{\circ}\text{C}$
Ambient temperature range	$T_{amb}$	-25 to +60	$^{\circ}\text{C}$
Storage temperature range	$T_{stg}$	-40 to +125	$^{\circ}\text{C}$
Power dissipation			
$T_{amb} = 60^{\circ}\text{C}$			
DIP 14	$P_{tot}$	860	mW
SO 16-L	$P_{tot}$	720	mW

## Thermal Resistance

Parameters	Symbol	Value	Unit
Junction ambient			
DIP 14	$R_{thJA}$	75	K/W
SO 16-L	$R_{thJA}$	90	K/W

## Electrical Characteristics

$V_S = 10\text{ V}$ ,  $f_{\text{clock}} = 455\text{ kHz}$ ,  $T_{\text{amb}} = 25\text{ to }60^\circ\text{C}$ . Reference point Pin 4 (5), Pin 13 (15) ground, unless otherwise specified.

Parameters	Test Conditions / Pins	Symbol	Min.	Typ.	Max.	Unit
Supply current (no load) outputs open $V_{6(7)} = 10\text{ V}$ $T_{\text{amb}} = +25^\circ\text{C}$	Pins 5 and 7 (6)	$I_S$	0.9	1.15	1.3	mA
Frequency range of the ringing input current a) Pin 1 – open b) Pin 1 – grounded c) Pin 1 – connected to Pin 6 (7)	Pins 5 and 7 (6, 8)	$f_{\text{ring}}$		23 to 54 12 to 54 DC operation		Hz
AC-operation Switch-on threshold Switch-off threshold	Pin 6 (7)			6.5 3.5	8.5 5.5	V
DC-operation Switch-on threshold Switch-off threshold Output on resistances at $\pm 20\text{ mA}$ Output signal frequency	Pin 6 (7) Pin 6 (7) Pin 11 (12) Pin 12 (13) Pins 11 and 12 (12,13)	$R_{\text{on}}$ $R_{\text{on}}$ $f_0$ $f_1$ $f_2$ $f_3$	2.75 2.0	448/455 800/812 1067/1083 1333/1354	4.75 4.0 400 400	V V W W kHz Hz Hz Hz
Build-up time of clock oscillator		$t_B$		10		ms
Internal voltage limitation $I_Z = 1\text{ mA}$	$V_{6-4}$ (7-5) Pin 6 (7)	25	27	30		V
Repetition rate oscillator: Low state High state Allowable resistor	Pin 8 (9) Pin 8 (9) Pins 8-10 (9-11)	$V_{8(9)}$ $V_{8(9)}$ $R$	0.5 0.043	0.6 2.0	0.7	V V M $\Omega$

## Ordering Information

Extended Type Number	Package	Remarks
U4076B-FL	SO 16	
U4076B	DIP 14	

## Dimensions in mm

Package: SO 16-L

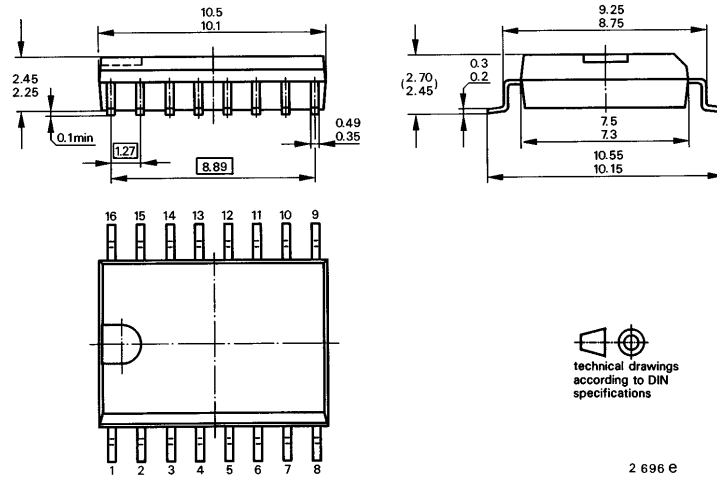

Package: DIP 14

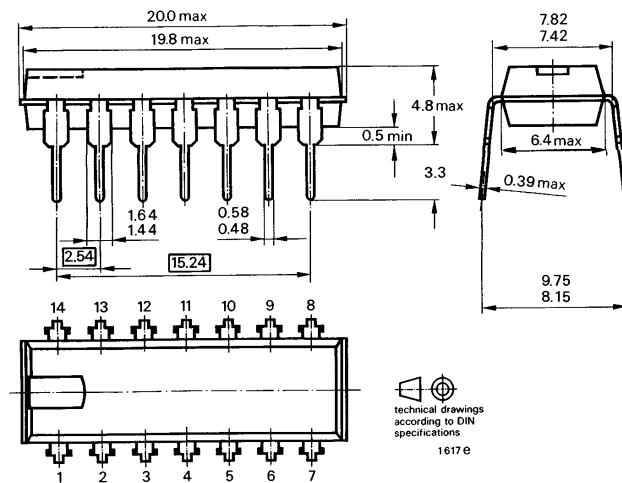

## Ozone Depleting Substances Policy Statement

It is the policy of **TEMIC TELEFUNKEN microelectronic GmbH** to

1. Meet all present and future national and international statutory requirements.
2. Regularly and continuously improve the performance of our products, processes, distribution and operating systems with respect to their impact on the health and safety of our employees and the public, as well as their impact on the environment.

It is particular concern to control or eliminate releases of those substances into the atmosphere which are known as ozone depleting substances (ODSs).

The Montreal Protocol (1987) and its London Amendments (1990) intend to severely restrict the use of ODSs and forbid their use within the next ten years. Various national and international initiatives are pressing for an earlier ban on these substances.

**TEMIC TELEFUNKEN microelectronic GmbH** semiconductor division has been able to use its policy of continuous improvements to eliminate the use of ODSs listed in the following documents.

1. Annex A, B and list of transitional substances of the Montreal Protocol and the London Amendments respectively
2. Class I and II ozone depleting substances in the Clean Air Act Amendments of 1990 by the Environmental Protection Agency (EPA) in the USA
3. Council Decision 88/540/EEC and 91/690/EEC Annex A, B and C (transitional substances) respectively.

**TEMIC** can certify that our semiconductors are not manufactured with ozone depleting substances and do not contain such substances.

**We reserve the right to make changes to improve technical design and may do so without further notice.**

Parameters can vary in different applications. All operating parameters must be validated for each customer application by the customer. Should the buyer use TEMIC products for any unintended or unauthorized application, the buyer shall indemnify TEMIC against all claims, costs, damages, and expenses, arising out of, directly or indirectly, any claim of personal damage, injury or death associated with such unintended or unauthorized use.

TEMIC TELEFUNKEN microelectronic GmbH, P.O.B. 3535, D-74025 Heilbronn, Germany  
Telephone: 49 (0)7131 67 2831, Fax number: 49 (0)7131 67 2423